

9 Piston Hydraulic Pump 910 Model ASEA-F 9 Pistonlu Hidrolik Pompa 910 Model ASEA-F

Code / Kod : EMC 940 085 03

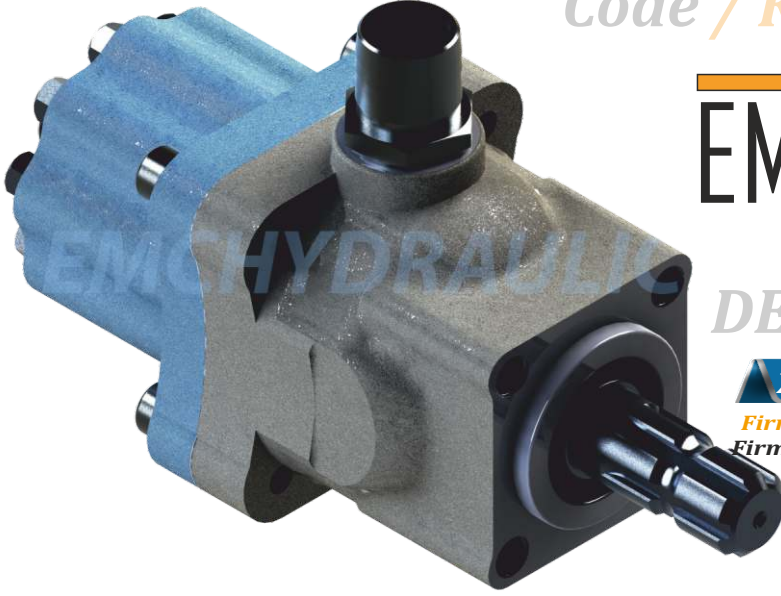

EMCHYDRAULIC

DECODING / KOD AÇILIMI



Firm Code
Firma Kodu



Product Type
Ürün Kodu



Liter
Litre (cm³)



Rotation
Dönüş Yönü

Tecnic Diagram

Teknik Diyagram !!!

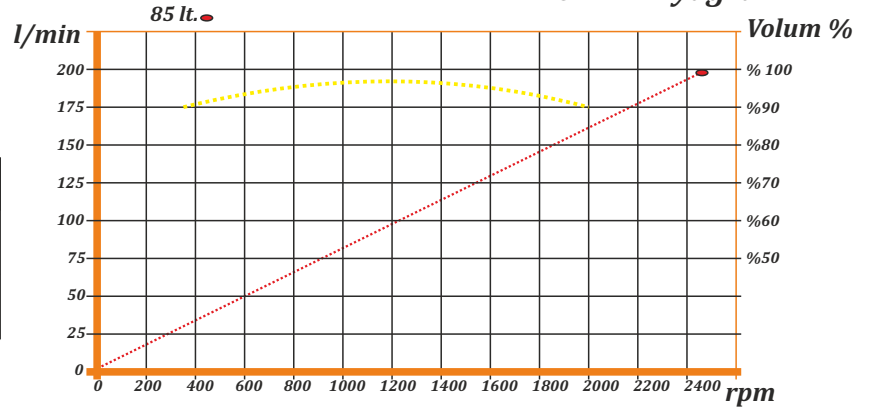

Tightening Torque

Sıkma Torkları !!!

Diameter / Diş Ölçüsü	M8	M10	M12
Screw and Nuts Torque Somun ve Çivata (Nm)	25	50	80
Studs Torque Saplamlar (Nm)	10	20	30

Technical Drawing

Teknik Çizim

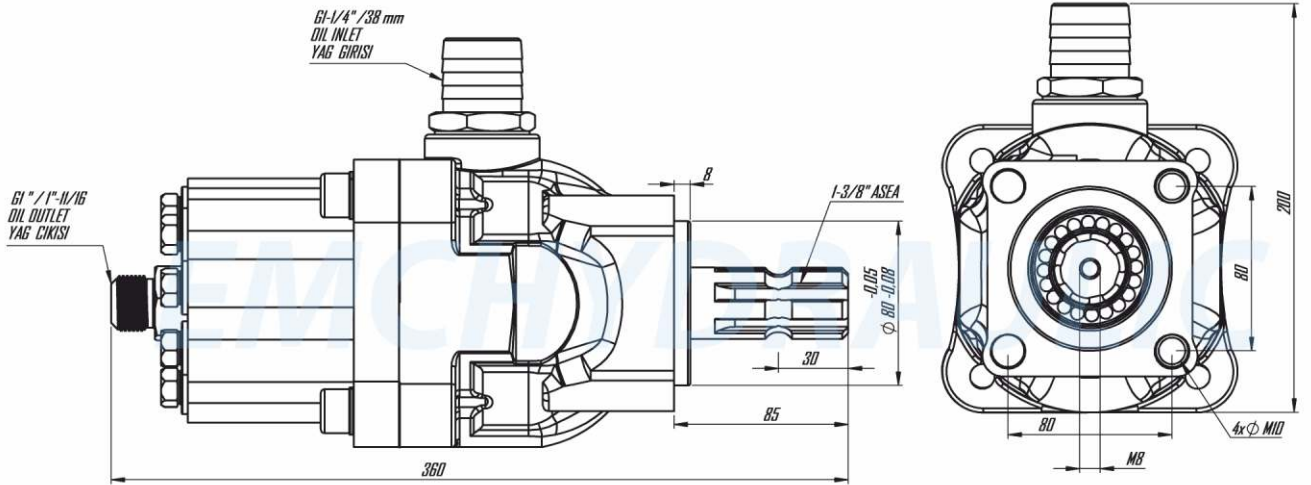

Technical Information

Teknik Veriler

Code Kod	Displacement Debi cm ³ /1000	Rotation Type Dönüş Yönü	Oil Inlet B Yağ Girişi B	Oil Outlet D Yağ Çıkışı D	Weight Ağırlık Kg
EMC 940 085 03	085	Bi Direction Çift Yönlü	1-1/4"	1"	20

Oil Temp./Sıvı Sıcaklığı
-10 C° + 90 C°

Inlet Pressure/Giriş Basıncı
0,7 ÷ 1,5 Bar

Viscosity / Viskosite
12 ÷ 100 cSt

Test Pressure / Test Basıncı
200 Bar (60 sec./saniye)

NOTE : The rotation of the pump has to be opposite with the rotation of PTO
NOT : Pompanın yönü ile PTO nun dönüş yönü ters olmalıdır.

Max. Test Pressure / Max. Test Basıncı
250 Bar (10 sec./saniye)

www.emchdraulic.com