

Power Take Off Isuzu Mxa 5 R 4,3 Mechanic
Güç Aktarma Kutusu Isuzu Mxa 5 R 4,3 Mekanik

EMCHYDRAULIC

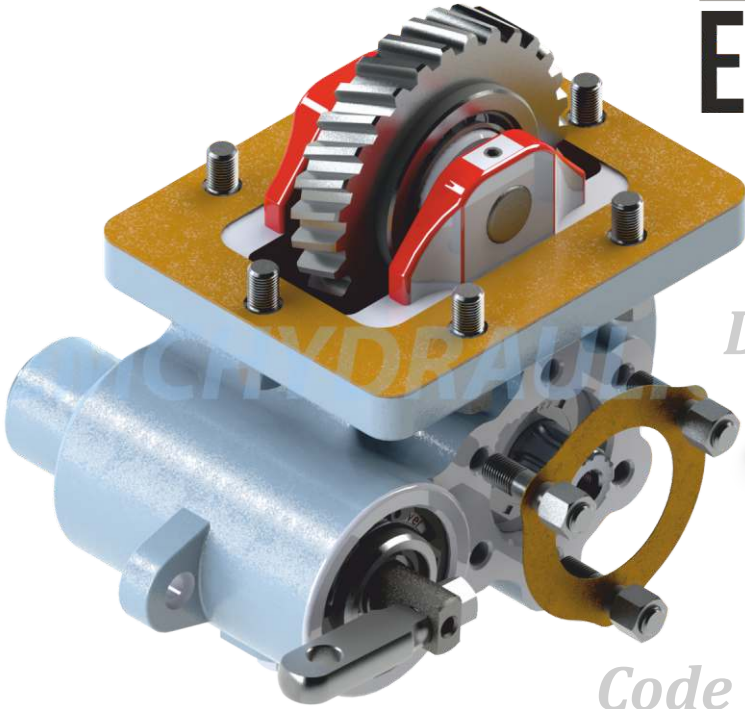

DECODING/KOD AÇILIMI

XXX	XXX	XXX	X
Firm Code Firma Kodu	Pto Type Araç Modeli	Type Ürün Kodu	Rotation Dönüş Yönü

Code / Kod : **EMC 206 421 2**

Tecnical Drawing
Teknik Çizim

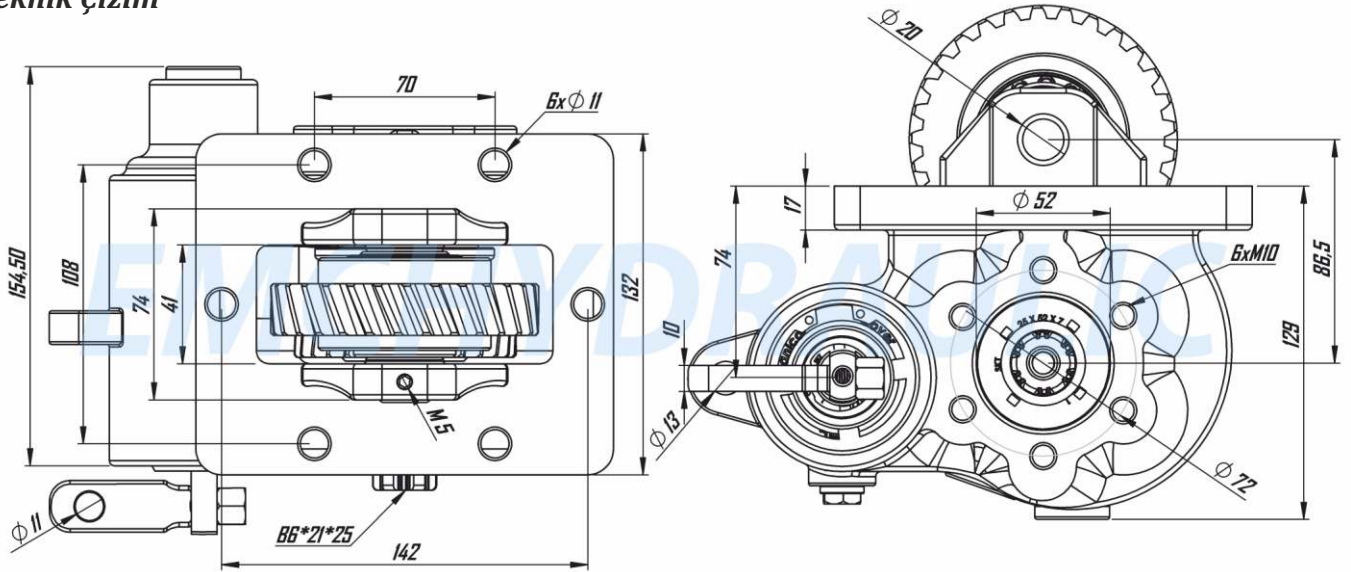

Tightening Torque
Sıkma Torkları !!!

Diameter / Diş Ölçüsü	M8	M10	M12
Screw and Nuts Torque Somun ve Çivata (Nm)	25	50	80
Studs Torque Saplamalar (Nm)	10	20	30

Tecnical Information
Teknik Veriler

Code Kod	Control Type Kumanda Tipi	Working Pressure Çalışma Basınç Bar	Rotation Dönüş	Output Çıkış Tipi	Mounting Type Bağlantı Şekli	Torque Tork Kgm	Rotation Oran	Weight Ağırlık Kg
EMC 206 421 2	Mechanic Mekanik	5-7 Bar	Right Sağ	UNI	Left Side Sol Yan	25 Kgm	1/1,2	10,5 Kg
Gear Box Model Pto Model Tipi	Isuzu NMXA 5 R*100 HP*5 R W 530*NKR 100 HP KAMYON*NKR 2.8 KAMYONET*NKR 5.0 KAMYON*NKR WIDE*NKR WIDE 66 *NKR-WIDE 66 KAMYON*NKR-WIDE KAMYON*NPR*NPR 4.3*NPR 66*NXA 5 R*WIDE*WIDE 100*WIDE 100							

NOTE : The rotation of the pump has to be opposite with the rotation of PTO
NOT : Pompanın yönü ile PTO nun dönüş yönü ters olmalıdır.

www.emchydraulic.com

EMCHYDRAULIC