

Power Take Off Mercedes 352  
Güç Aktarma Kutusu Mercedes 352

# EMCHYDRAULIC



DECODING/KOD AÇILIMI

<b>Firm Code</b> Firma Kodu	<b>Pto Type</b> Araç Modeli	<b>Type</b> Ürün Kodu	<b>Rotation</b> Dönüş Yönü
--------------------------------	--------------------------------	--------------------------	-------------------------------

Code / Kod : **EMC 202 332 2**

**Technical Drawing**  
Teknik Çizim

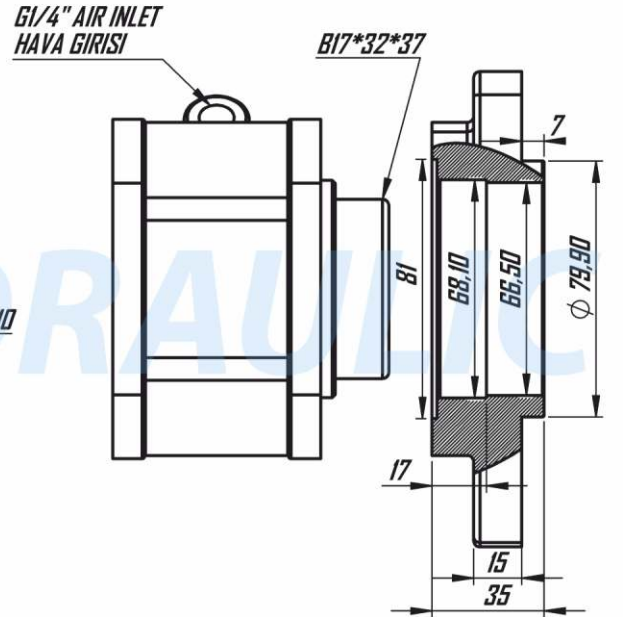
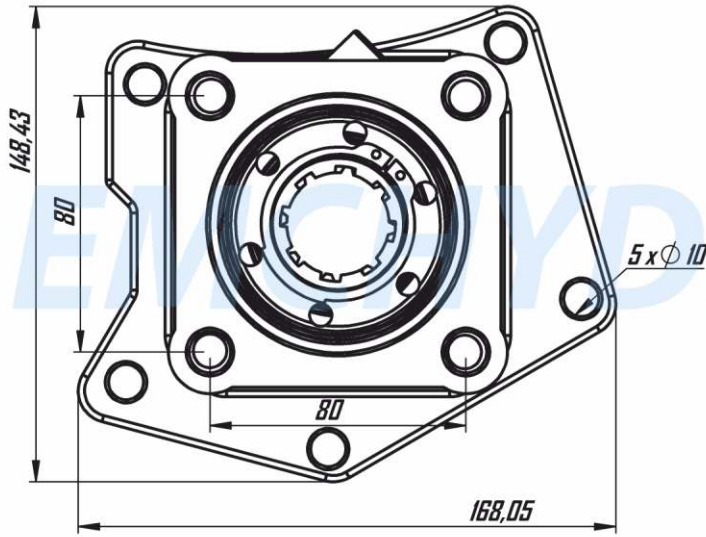

**Tightening Torque**  
Sıkma Torkları !!!

Diameter / Diş Ölçüsü	M8	M10	M12
Screw and Nuts Torque Somun ve Çivata (Nm)	25	50	80
Studs Torque Saplamalar (Nm)	10	20	30

**Technical Information**  
Teknik Veriler

Code Kod	Control Type Kumanda Tipi	Working Pressure Çalışma Basıncı Bar	Rotation Dönüş	Output Çıkış Tipi	Mounting Type Bağlantı Şekli	Torque Tork Kgm	Rotation Oran	Weight Ağırlık Kg
EMC 202 332 2	Pneumatic Havali	7-12 Bar	Right Sağ	ISO	Rear Type Kuyruk	45 Kgm	1/1	4 Kg
Gear Box Model Pto Model Tipi	<b>Mercedes</b> 352*G 3/50*G 5/75*G 51302*G 52302							

**NOTE :** The rotation of the pump has to be opposite with the rotation of PTO  
**NOT :** Pompanın yönü ile PTO nun dönüş yönü ters olmalıdır.

www.emchydraulic.com

EMCHYDRAULIC