

Power Take Off Volvo R 1700
Güç Aktarma Kutusu Volvo R 1700

EMCHYDRAULIC

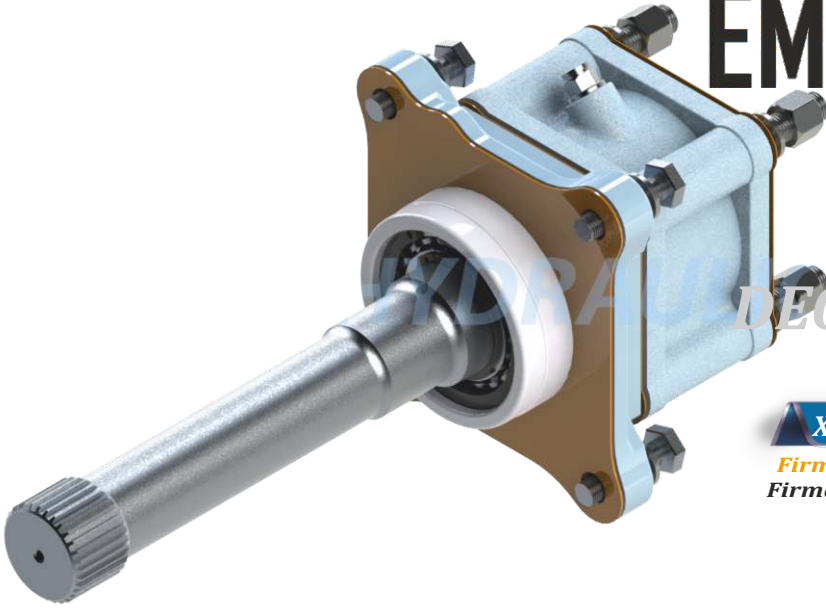

DECODING / KOD AÇILIMI

XXX
Firm Code
Firma Kodu

XX
Pto Type
Araç Modeli

XX
Type
Ürün Kodu

XX
Rotation
Dönüş Yönü

Code / Kod : EMC 203 502 2

Tecnical Drawing Teknik Çizim

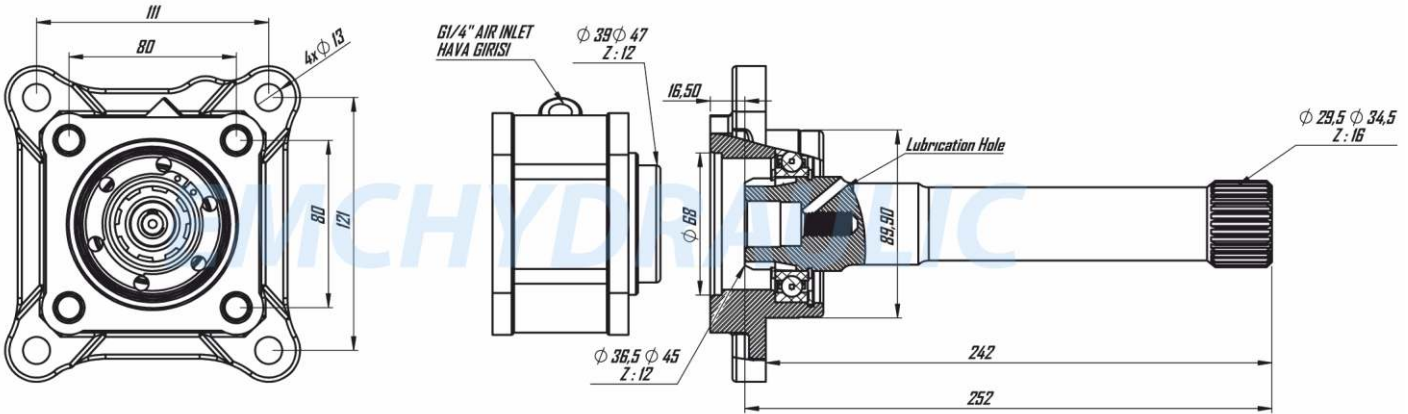

Tightening Torque Sıkma Torkları !!!

Diameter / Diş Ölçüsü	M8	M10	M12
Screw and Nuts Torque Somun ve Çivata (Nm)	25	50	80
Studs Torque Saplamalar (Nm)	10	20	30

Tecnical Information Teknik Veriler

Code Kod	Control Type Kumanda Tipi	Working Pressure Çalışma Basıncı Bar	Rotation Dönüş	Output Çıkış Tipi	Mounting Type Bağlantı Şekli	Torque Tork Kgm	Rotation Oran	Weight Ağırlık Kg
EMC 203 502 2	Pneumatic Havali	7-12 Bar	Right Sağ	ISO	Rear Type Kuyruk	45 Kgm	1/1	8 Kg
Gear Box Model Pto Model Tipi	VOLVO R 1700*R 1000*R 1400* R 1440*VOLVO TF 10*TF 12*TF 16*TFL 10*TFL 7*TN 10* 2214*V 2514*VT 2214 *VT2214 BV*SR 1400*SR 1700*420* 440*SR 1900*SR 2000*SR 400*SRO 2400*N 10*N 10 6x4*N 12*NL 12*F 10*F 12*F 12 F *F 12 FS*F 12 INTERCOOLER 400*F 16*F 16 F 6x2*F 7 F*VT 2514*VT 2514 B*FH*FH 12*FH 16 (520)*FH 420 HP 42T 4x2 ÇEKİCİ Euro5 *FH 460 HP 42T 4x2 Çkç Euro5*FH 500 HP 42T 4x2 Çkç Euro5*FL 10*FL 616*FL 617*FL 7*FL 7 4x2*FL 7 6x2*FL 7 FS*FM 400 *FM 390 HP 42T 4x2 Çkç Euro4*FM 430 HP 42T 4x2 Çkç Euro4*FM 440 HP 64 6x4 Dumper Euro4*FM 480 HP 64 6x4 Euro4							

NOTE : The rotation of the pump has to be opposite with the rotation of PTO
NOT : Pompanın yönü ile PTO nun dönüş yönü ters olmalıdır.