

Hydraulic Limiter Control Valve Hidrolik Sınır Control Ventili

Code / Kod : EMC 230 090 00



EMCHYDRAULIC

DECODING/KOD AÇILIMI

XXX	XXX	XXX	XX
Firm Code Firma Kodu	Valve Type Valf Modeli	Liter Litre (cm ³)	Desing Tasarım Kodu

Tecnic Diagram
Teknik Diyagram !!!

Tightening Torque Sıkma Torkları !!!

Diameter / Diş Ölçüsü	M8	M10	M12
Screw and Nuts Torque Somun ve Çivata (Nm)	25	50	80
Studs Torque Saplamalar (Nm)	10	20	30

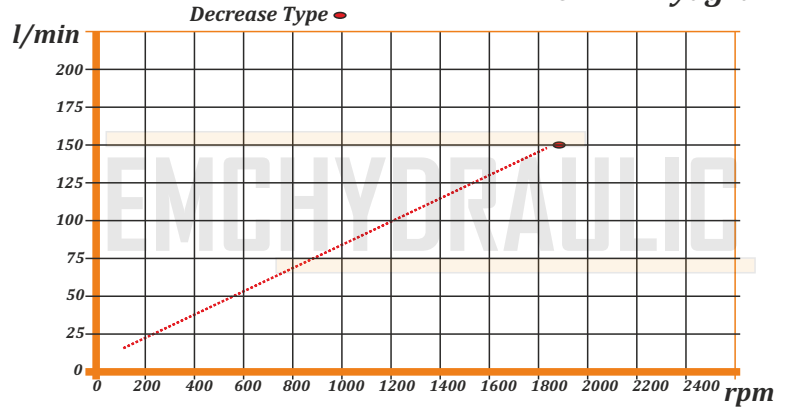

Tecnical Drawing Teknik Çizim

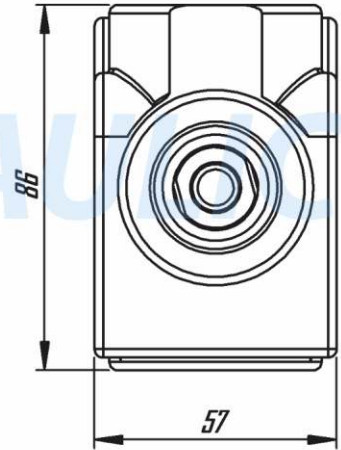
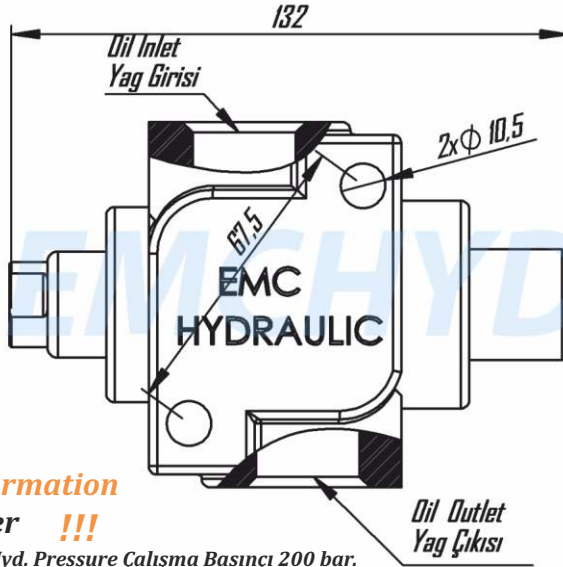

Tecnical Information Teknik Veriler !!!

NOTE : Working Hyd. Pressure Çalışma Basıncı 200 bar.
NOTE : Nodular cast-iron body for pressure up to 400 bar.
NOTE : Test Pressure : 60 sec / Max Test Pressure : 5 sec. Max

NOT : Çalışma Basıncı 200 bar.

NOT : 400 bar basınç up Sfero döküm gövde.

NOT : Test basınç süresi 60 saniye / max. test basınç süresi 5 saniye dir.

Code Kod	Flow rate Debi	Control Type Kumanda Tipi	Oil Inlet Pump Yağ Girişi	Oil Outlet Cylinder Yağ Çıkışı	W. Hyd. Pres. Çalışma Basıncı Bar	Operating Viscosity Vizkosite	Oil Filtering Filtre	Weight Ağırlık Kg
EMC 230 090 00	090 lt/dak	Mechanic Mekanik	3/4"	3/4"	200	-12-100 cSt	> 200 bar : 25um <200 bar : 35 um	1,8 Kg